



ISO9001
ISO 14001
OHSAS 18001

CE

INNOBIZ / VENTURE / GOOD EXPORTING COMPANY

PL-INSURANCE

EXPLOSION PROOF

KOTRA SEAL

HOIST & CRANE

The best support for the best products



CHAIN HOIST
WIRE ROPE HOIST
CRANE COMPONENTS

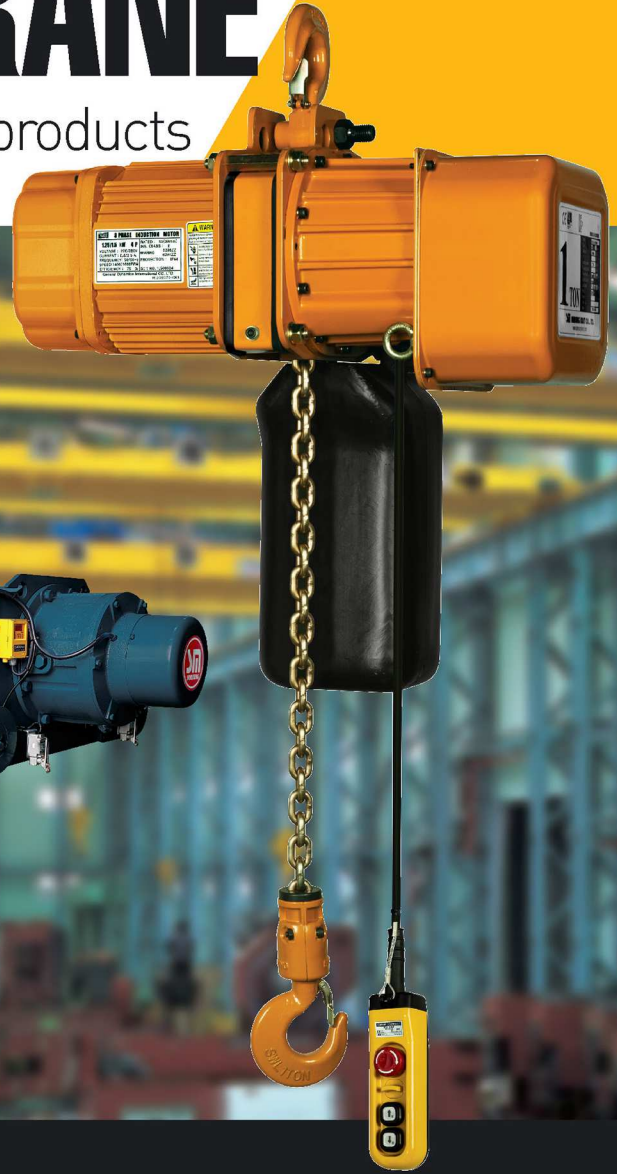

Synonymous with construction, transportation,
loading and unloading machinery



SAMSUNG HOIST CO., LTD.

With the accumulated technology & continuous quality improvement will create a hopeful future of material handling machines

SAMSUNG HOIST



SAMSUNG HOIST CO., LTD. It's has been focusing on producing transporting technology machinery such as hoist and crane since it was founded in 1989. As a leading manufacturer. Our company is making real effort to play a more active role in the same field at domestic and overseas market.

We're so proud of our products because we're not only producing them with accumulating technology but also exporting them to those worldwide areas such as Europe, North and South America, Southeast Asia, the Middle East and Africa countries.

With more challenging and creative mind. We promise to strengthen the bonds between our company and all new partners. As a responsible and reliable company. We'll always give top priority to your company's safety and improvement of your productivity.

In addition we also do our best to inform you the latest and the most useful information and technology. So you can always trust us.

Thank you.

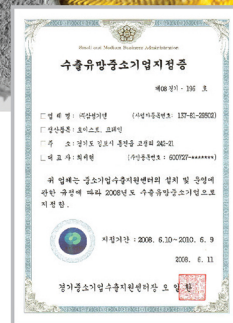

Promising Export SME



Development Department

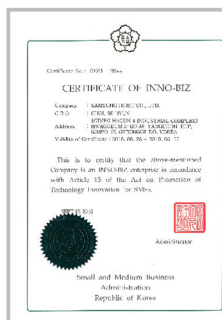

INNO-BIZ



ISO 9001



ISO 14001

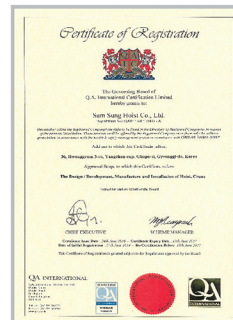

OHSAS 18001



CE

HISTORY

- 1989** Found "Central Industrial Machinery"
- 1990** Started the core parts, Hoists and Cranes production
- 1992** Started the core parts, Geared Motor production
- 1995** Started the country's first All-Aluminum Body Hoist production
- 1996** Changed the firm name to "SAMSUNG MACHINERY"
- 2000** Incorporated the firm "SAMSUNG MACHINERY CO., LTD."
- 2002** Acquired the certification ISO 9001
- 2003** Started the mass production of Low head room Mono Rail Hoist
- 2004** 2004 Presented Low head room Double Rail Hoist
In Gimpo-si, completed the office building and the factory exclusive use for Hoist and Crane
- 2005** Proposed Corn-Brake type "SM" Hoist [0.25 ~ 2 Ton]
- 2006** Proposed 3 Ton Slip Clutch type Hoist / 3, 5, 7.5, 10 Ton "SM" Hoist
- 2007** Certified INNO-BIZ company, Registered Venture Business,
Proposed the Single phase Hoist
Certified Enterprise Institute [Department for research]
- 2008** Certified Promising Export Small and Medium Business Administration
Presented 1, 2, 3 Ton prevention of explosion type Hoist
- 2009** Certified KOTRA sponsorship brand
- 2010** SAMSUNG MACHINERY CO., LTD. second factory in Hwasung-si was completed.
Signed technical cooperation contract MOU with Korea Gorbelt
Selected enterprise of export 500 at the small and medium business administration
- 2016** In Gimpo Golden Valley [Gimpo Hagun 4 Industrial Complex] completed
the new office building and the factory exclusive use for Hoist and Crane
Changed the firm name to "SAMSUNG HOIST CO., LTD."

CHAIN HOIST

- 06** SUSPENSION TYPE
- 08** MOTOR TROLLEY TYPE
- 10** SINGLE PHASE HOIST
- 12** INVERTER TYPE
- 14** SPECIAL TYPE
- 15** -LOW HEAD TYPE
- 15** -EXPLOSION PROOF TYPE



PRODUCTS GUIDE

Main Products

Chain hoist



Suspension Type
0.25ton~30ton



Motor trolley Type
0.25ton~30ton



Low-Head Type
1ton~5ton



Single Phase Hoist
0.25ton~3ton

Wire rope hoist



Regular Type
0.5ton~20ton



Double-Rail Type
2ton~30ton

Wireless remote control



Crane & Components of crane



Crane



Saddle



Geared motor



Panel

Selection Criteria

You can use CHAIN HOIST for a long time without any trouble if you select it properly according

Samsung Electric Chain Hoists are allocated to mechanism groups in accordance with the following regulations. Under the allowance of the following mechanism groups, the hoist should be operated and should not exceed the nominal values. On each identification plate, the following is indicated.

Hook suspension chain hoist : FEM 9.511 (Hoist = FEM 2m 40% ED)

Motor trolley mounted series : FEM 9.511 (Hoist/Trolley + FEM 2m 1Am 40 / 25% ED) Starting frequency = 240 time/Hr.

FEM Mechanism Group 9.511

(Rules for Design of Serial Lifting Equipment : Classification of Mechanism)

Mechanism group	1Bm	1Am	2m	3m	4m	5m
Load group	Average operating period per day (h)					
Light $k < 0.50$	<2	2-4	4-8	8-16	>16	
Medium $0.50 < k < 0.63$	<1	1-2	2-4	4-8	8-16	>16
Heavy $0.30 < k < 0.80$	<0.5	0.5-1	1-2	2-4	4-8	8-16
Very Heavy $0.80 < k < 1.00$	<0.25	<0.5	0.5-1	1-2	2-4	4-8

AIMING TO BETTER TECHNOLOGY & CUSTOMER SAFETY

Domestic & Foreign periods based on accumulated technology and heavy industry and construction, committed to playing a leading role in the material handling field

Explanation of Hoist Designation

SM	T	-	S	1000	D	-	SP
Samsung Chain hoist	Travesing method		Hoisting speed	Hoist capacity (kg)	Num of Chain		Other
	O Ordinary type T Motor driven trolley L Low head type		S Single Speed D Dual speed	1000kg 2000kg...	No Mark 1fall D Several falls		SP Single Phase IV Inverter EV Event

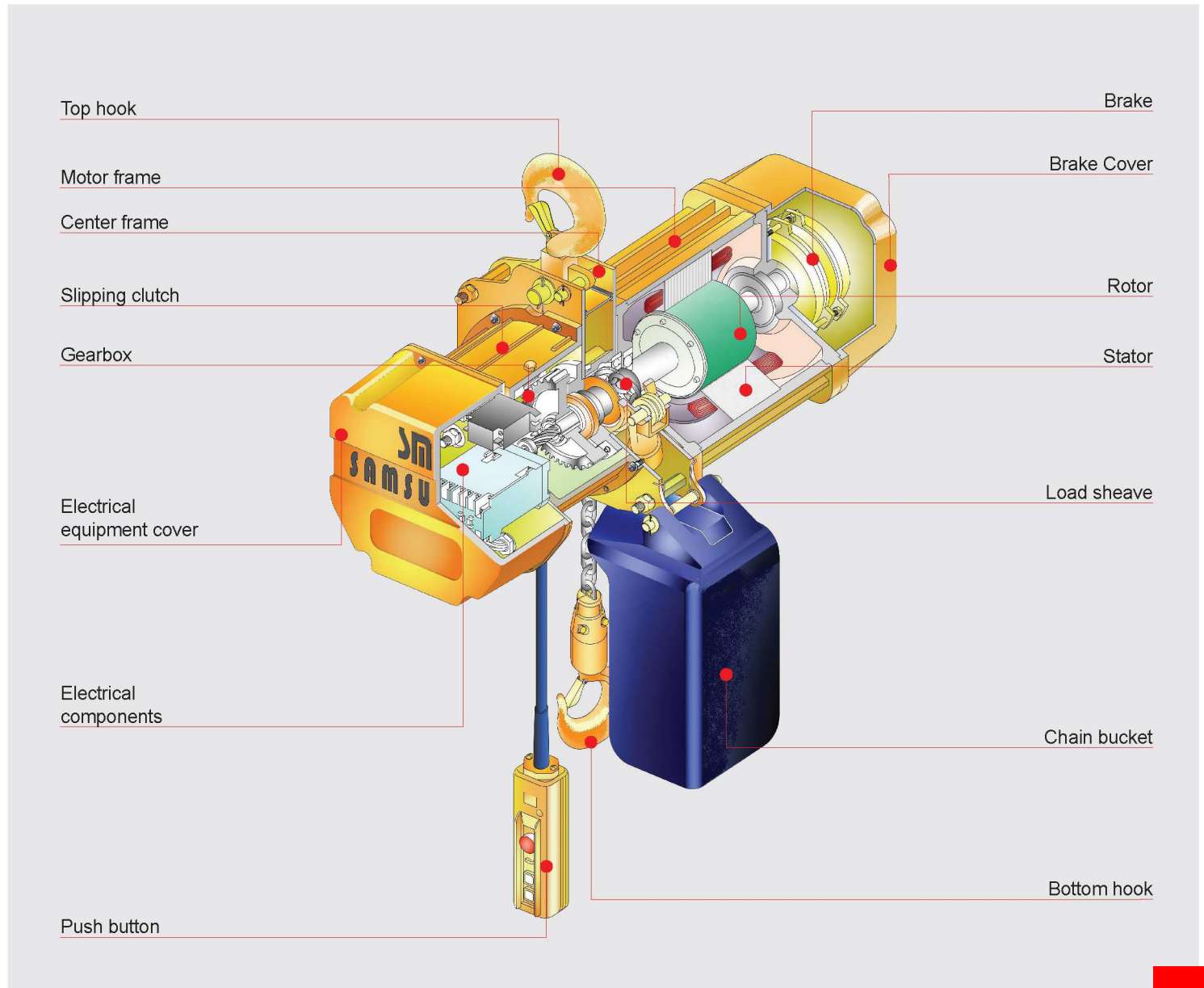

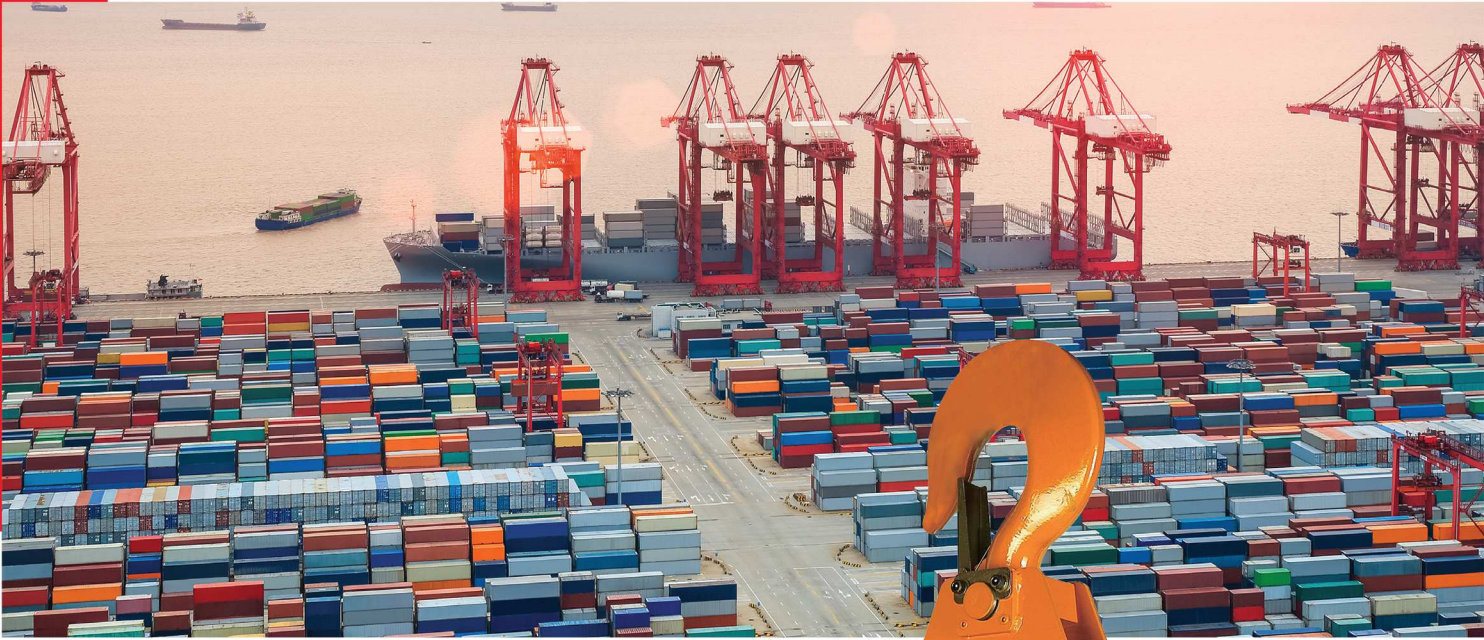

- Motors and brakes that boast powerful and long life
- Aluminum alloy frame that minimizes weight
- Voltage operation mode that minimizes the human body electric shock
- It using a high strength and stability RUD(Made in Germany), FED(Made in Japan)
- Deceleration of the structure and durable material benefits that boasts ultra-quiet
- Uniform production control system to produce quality

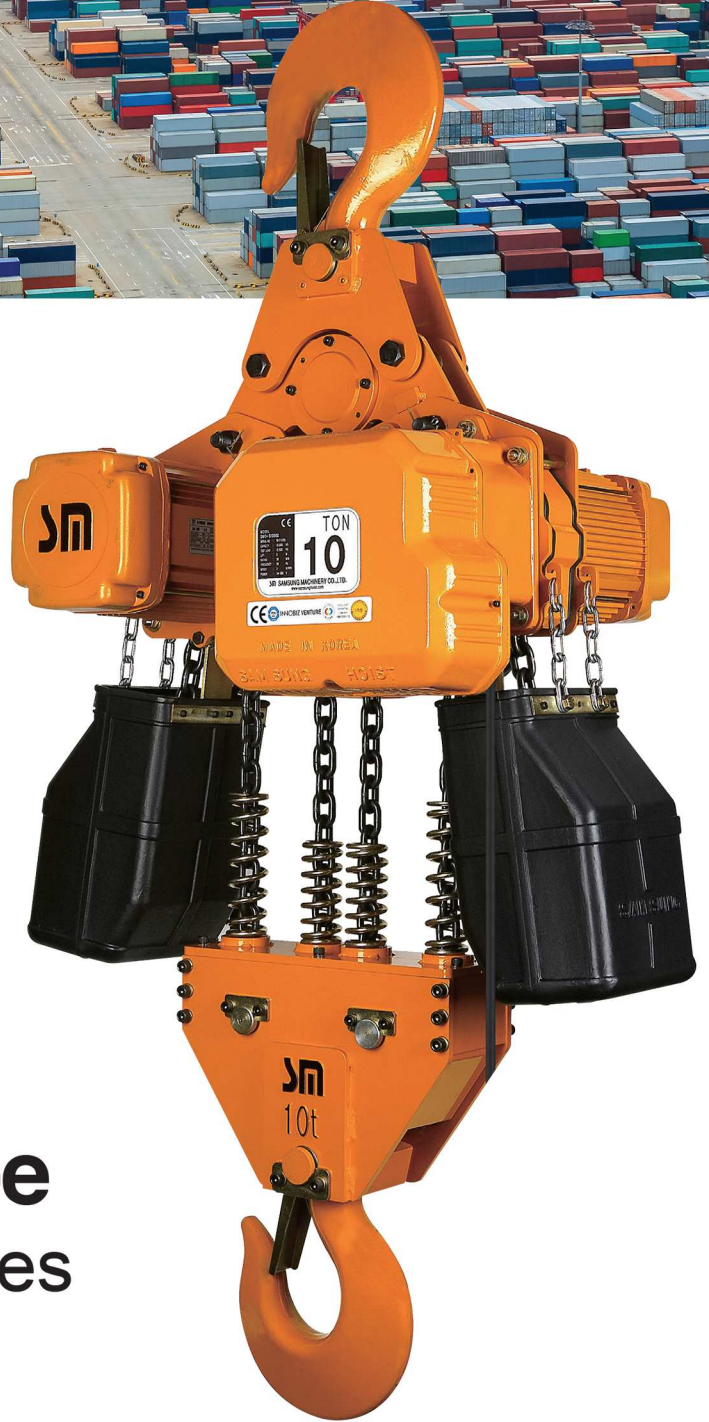

Chain hoist
Suspension Type
SMO series

Frame	Model	Capacity (kg)	Hoisting Motor [Single]				Hoisting Motor [Dual]				Load Chain (mm×Falls)	Net Weight (kg)	Dimension					
			Power(kw)		Speed(m/min)		Power(kw)		Speed(m/min)				Single					Dual
			50Hz	60Hz	50Hz	60Hz	50Hz	60Hz	50Hz	60Hz			A	B	C	D	E	A
A	SWO-S(D)250	250	0.42×4P	0.5×4P	4.6	5.6	0.42/0.21×4/8P	0.5/0.25×4/8P	4.7/2.4	5.6/2.8	Ø5.0×1	36	240	196	157	165	410	257
			0.42×4P	0.5×4P	7.0	8.4	0.42/0.21×4/8P	0.5/0.25×4/8P	7.0/3.5	8.4/4.2	Ø5.0×1	36	240	196	157	165	410	257
	SWO-S(D)500	500	0.54×4P	0.65×4P	4.6	5.6	0.58/0.19×4/12P	0.7/0.23×4/12P	4.7/1.6	5.6/1.9	Ø5.0×1	38	240	196	157	165	410	265
			0.92×4P	1.1×4P	7.0	8.4	-	-	-	-	Ø5.0×1	38	257	196	157	165	410	-
B	SWO-S(D)1000	1000	1.25×4P	1.5×4P	5.8	7.0	1.25/0.63×4/8P	1.5/0.75×4/8P	5.8/2.9	7.0/3.5	Ø7.1×1	60	295	245	139	210	440	335
	SWO-S(D)1250	1250	1.7×4P	2.0×4P	5.8	7.0	1.25/0.63×4/8P	1.5/0.75×4/8P	5.8/2.9	7.0/3.5	Ø7.1×1	60	295	245	139	210	440	335
	SWO-S(D)1500	1500	2.1×4P	2.5×4P	6.7	8.0	2.1/1.05×4/8P	2.5/1.25×4/8P	6.7/3.4	8.0/4.0	Ø8.0×1	65	295	245	141	216	490	335
	SWO-S(D)1800D	1800	1.25×4P	1.5×4P	2.9	3.5	1.25/0.63×4/8P	1.5/0.75×4/8P	2.9/1.5	3.5/1.8	Ø7.1×2	68	295	245	106	245	552	335
	SWO-S(D)2000D	2000	1.25×4P	1.5×4P	2.9	3.5	1.25/0.63×4/8P	1.5/0.75×4/8P	2.9/1.5	3.5/1.8	Ø7.1×2	68	295	245	106	245	552	335
	SWO-S(D)2500D	2500	1.7×4P	2.0×4P	2.9	3.5	1.25/0.63×4/8P	1.5/0.75×4/8P	2.9/1.5	3.5/1.8	Ø7.1×2	68	295	245	106	245	552	335
	SWO-S(D)3000D	3000	2.1×4P	2.5×4P	3.4	4.0	2.1/1.05×4/8P	2.5/1.25×4/8P	3.4/1.7	4.0/2.0	Ø8.0×2	72	295	245	100	261	660	335
	C	SWO-S(D)2000	2000	2.9×4P	3.5×4P	6.8	8.2	2.9/1.5×4/8P	3.5/1.75×4/8P	6.8/3.4	8.2/4.1	Ø11.2×1	110	348	313	189	271	770
SWO-S(D)3000		3000	2.9×4P	3.5×4P	5.0	6.0	2.9/1.5×4/8P	3.5/1.75×4/8P	5.0/2.5	6.0/3.0	Ø11.2×1	110	348	313	189	271	690	388
SWO-S(D)5000D		5000	2.9×4P	3.5×4P	2.5	3.0	2.9/1.5×4/8P	3.5/1.75×4/8P	2.5/1.3	3.0/1.5	Ø11.2×2	126	348	313	115	346	980	388
SWO-S(D)7500D		7500	2.9×4P	3.5×4P	1.7	2.0	2.9/1.5×4/8P	3.5/1.75×4/8P	1.7/0.8	2.0/1.0	Ø11.2×3	318	385	325	190	430	1440	390
SWO-S(D)10000D		10000	2.9×4P	3.5×4P	2.5	3.0	2.9/1.5×4/8P	3.5/1.75×4/8P	2.5/1.3	3.0/1.5	Ø11.2×4	424	385	385	465	465	1440	390



A-Frame 250~500kg

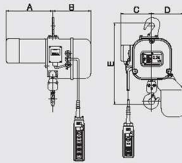

B-Frame 1000~3000kg(2falls)

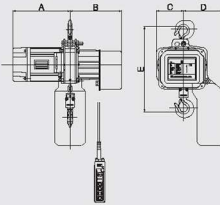

C-Frame 3000kg

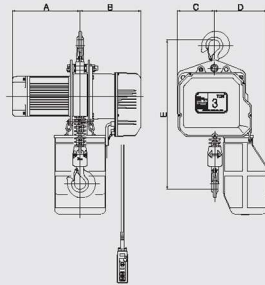

C-Frame 5000kg

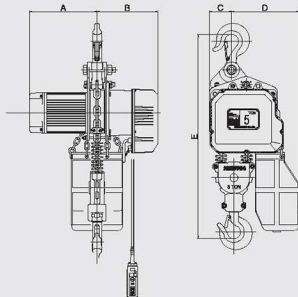

C-Frame 7500kg

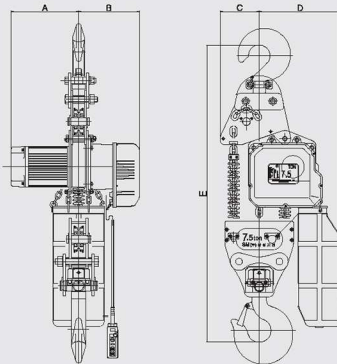

C-Frame 10000kg

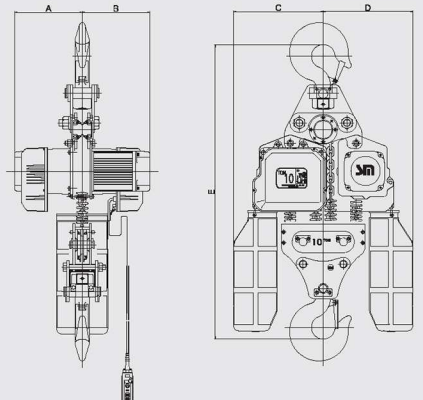



- Motors and brakes that boast powerful and long life
- Aluminum alloy frame that minimizes weight
- Voltage operation mode that minimizes the human body electric shock
- It using a high strength and stability RUD(Made in Germany), FED(Made in Japan)
- Deceleration of the structure and durable material benefits that boasts ultra-quiet
- Uniform production control system to produce quality



Chain hoist
Motor Trolley Type
SMT series

Frame	Model	Capacity (kg)	Hoisting Motor [Single]				Hoisting Motor [Dual]				Traversing Motor				Load Chain (mm×Falls)	Net Weight (kg)	I-Beam Width (mm)	Min.Radius For Curve (mm)	Dimension					
			Power(kw)×Pole		Speed(m/min)		Power(kw) × Pole		Speed(m/min)		Power(kw)×Pole		Speed(m/min)						Single			Dual		
			50Hz	60Hz	50Hz	60Hz	50Hz	60Hz	50Hz	60Hz	50Hz	60Hz	50Hz	60Hz					A	B	C	D	E	A
A	SMT-S(D)250	250	0.42×4P	0.5×4P	4.7	5.6	0.42/0.21×4/8P	0.5/0.25×4/8P	4.7/2.4	5.6/2.8	0.33×4P (0.22×6P) [0.17×8P]	0.4×4P (0.27×6P) [0.2×8P]	16.7 (11.1) [8.3]	20.0 (13.3) [10.0]	Ø5.0×1	62	75~125	1200	335	238	130	193	444	355
			0.42×4P	0.5×4P	7.0	8.4	0.42/0.21×4/8P	0.5/0.25×4/8P	7.0/3.5	8.4/4.2					Ø5.0×1	62	75~125	1200	335	238	130	193	444	355
	SMT-S(D)490	490	0.54×4P	0.65×4P	4.7	5.6	0.42/0.21×4/8P	0.5/0.17×4/8P	4.7/2.4	5.6/2.8					Ø5.0×1	64	75~125	1200	335	238	130	193	444	355
			0.54×4P	0.65×4P	4.7	5.6	0.63/0.21×4/12P	0.75/0.23×4/12P	4.7/1.6	5.6/1.9					Ø5.0×1	64	75~125	1200	335	238	130	193	444	355
	SMT-S(D)500	500	0.92×4P	1.1×4P	7.0	8.4	-	-	-	-					Ø5.0×1	64	75~125	1200	335	238	130	193	452	355
B			SMT-S(D)1000	1000	1.25×4P	1.5×4P	5.8	7.0	1.25/0.63×4/8P	1.5/0.75×4/8P	5.8/2.9	7.0/3.5	0.33×4P (0.22×6P) [0.17×8P]	0.4×4P (0.27×6P) [0.2×8P]	15.8 (10.0) [7.9]	19.0 (12.0) [9.5]	Ø7.1×1	82	75~125	1200	295	335	139	212
	SMT-S(D)1250	1250			1.7×4P	2.0×4P	5.8	7.0	1.25/0.63×4/8P	1.5/0.75×4/8P	5.8/2.9	7.0/3.5					Ø7.1×1	82	75~125	1200	295	335	139	212
	SMT-S(D)1500	1500	2.1×4P	2.5×4P	6.7	8.0	2.1/1.25×4/8P	2.5/1.25×4/8P	6.7/3.4	8.0/4.0	Ø8.0×1	90					100~150	1500	295	365	140	213	460	335
	SMT-S(D)1800D	1800	1.25×4P	1.5×4P	2.9	3.5	1.25/0.63×4/8P	1.5/0.75×4/8P	2.9/1.5	3.5/1.8	Ø7.1×2	102					100~150	1500	295	365	140	245	530	335
	SMT-S(D)2000D	2000	1.25×4P	1.5×4P	2.9	3.5	1.25/0.63×4/8P	1.5/0.75×4/8P	2.9/1.5	3.5/1.8	Ø7.1×2	102					100~150	1500	295	365	140	245	530	335
	SMT-S(D)2500D	2500	1.7×4P	2.0×4P	2.9	3.5	1.25/0.63×4/8P	1.5/0.75×4/8P	2.9/1.5	3.5/1.8	Ø7.1×2	102					100~150	1500	295	365	140	245	530	335
	SMT-S(D)3000D	3000	2.1×4P	2.5×4P	3.4	4.0	2.1/1.25×4/8P	2.5/1.25×4/8P	3.4/1.7	4.0/2.0	Ø8.0×2	115					100~150	1500	295	365	140	308	610	335
C	SMT-S(D)2000	2000	2.9×4P	3.5×4P	6.8	8.2	2.9/1.5×4/8P	3.5/1.75×4/8P	6.8/3.4	8.2/4.1	0.33×4P (0.22×6P) [0.17×8P]	0.4×4P (0.27×6P) [0.2×8P]	13.3 (8.3) [6.7]	16.0 (10.0) [8.0]	Ø11.2×1	135	100~150	1500	353	313	190	271	650	386
			SMT-S(D)3000	3000	2.9×4P	3.5×4P	5.0	6.0	2.9/1.5×4/8P	3.5/1.75×4/8P					5.0/2.5	6.0/3.0	Ø11.2×1	135	100~150	1500	353	313	190	271
	SMT-S(D)5000D	5000	2.9×4P	3.5×4P	2.5	3.0	2.9/1.5×4/8P	3.5/1.75×4/8P	2.5/1.3	3.0/1.5					Ø11.2×2	194	125~175	2000	370	313	200	337	880	405
			SMT-S(D)7500D	7500	2.9×4P	3.5×4P	1.7	2.0	2.9/1.5×4/8P	3.5/1.75×4/8P					1.7/0.8	2.0/1.0	Ø11.2×3	384	125~175	2000	465	330	260	430
	SMT-S(D)10000D	10000	2.9×4P	3.5×4P	2.5	3.0	2.9/1.5×4/8P	3.5/1.75×4/8P	2.5/1.3	3.0/1.5					1.25×4P	1.5×4P	12.5	15	Ø11.2×4	524	125~175	2000	465	390

Traversing motor : 50Hz is standard 4P, 60Hz is standard 6P

A-Frame 250~500kg

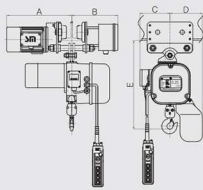

B-Frame 1000~3000kg(2falls)

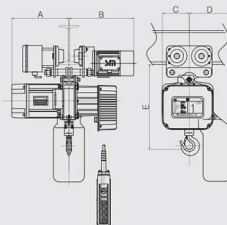

C-Frame 3000kg

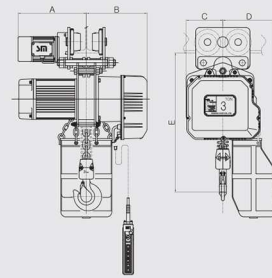

C-Frame 5000kg

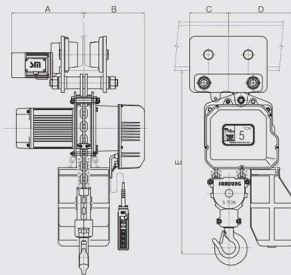

C-Frame 7500kg

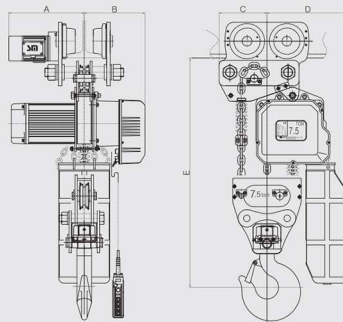

C-Frame 10000kg

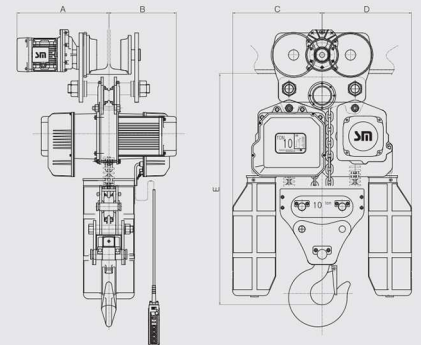



- Motors and brakes that boast powerful and long life
- Aluminum alloy frame that minimizes weight
- Voltage operation mode that minimizes the human body electric shock
- It using a high strength and stability RUD(Made in Germany), FED(Made in Japan)
- Deceleration of the structure and durable material benefits that boasts ultra-quiet
- Uniform production control system to produce quality

Powerful Performance

Excellent Performance Including When Lower Voltage Lifting up to The Weight of 1.25 Times Heavier Then Rated Weight.

Enough Working Time

Over 20 Minutes of Running Time as Like 3 Phase Hoist.

Chain hoist
Single Phase Type

SP series

Standard

Frame	Model	Capacity (kg)	Hoisting Motor [Single]				Load Chain (mm×Falls)	Net. Weight (kg)	Dimension				
			Power(kw)×Pole		Speed(m/min)				Single				
			50Hz	60Hz	50Hz	60Hz			A	B	C	D	E
A	SMO-S250-SP	250	0.42×4P	0.5×4P	4.6	5.6	Ø5.0×1	36	240	196	157	165	410
			0.42×4P	0.5×4P	7.0	8.4	Ø5.0×1	36	240	196	157	165	410
	SMT-S(D)490	490	0.54×4P	0.65×4P	4.6	5.6	Ø5.0×1	38	240	196	157	165	410
	SMO-S(D)500	500	0.54×4P	0.65×4P	4.6	5.6	Ø5.0×1	38	240	196	157	165	410
			0.92×4P	1.1×4P	7.0	8.4	Ø5.0×1	38	257	196	157	165	410
B	SMT-S(D)1000	1000	1.25×4P	1.5×4P	5.8	7.0	Ø7.1×1	60	295	245	139	210	440
	SMT-S(D)1800D	1800	1.25×4P	1.5×4P	2.9	3.5	Ø7.1×2	68	295	245	106	245	552
	SMT-S(D)2000D	2000	1.25×4P	1.5×4P	2.9	3.5	Ø7.1×2	68	295	245	106	245	552



A-Frame 250~500kg

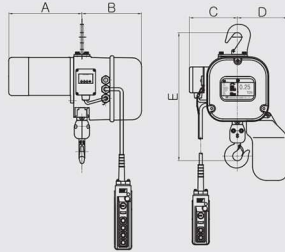

B-Frame 1000~3000kg

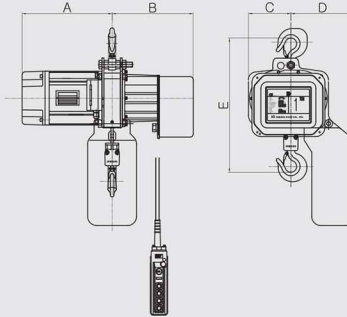

Standard

Frame	Model	Capacity (kg)	Hoisting Motor [Single]				Traversing Motor				Load Chain (mm×Falls)	Net. Weight (kg)	I-Beam Width (mm)	Min. Radius For Curve (mm)	Dimension				
			Power(kw)×Pole		Speed(m/min)		Power(kw)×Pole		Speed(m/min)						Single				
			50Hz	60Hz	50Hz	60Hz	50Hz	60Hz	50Hz	60Hz					A	B	C	D	E
A	SMT-S(D)250	250	0.42×4P	0.5×4P	4.6	5.6	0.33×4P	0.4×4P	16.7	20.0	Ø5.0×1	62	75~125	1200	335	238	130	193	444
			0.42×4P	0.5×4P	7.0	8.4	0.33×4P	0.4×4P	16.7	20.0	Ø5.0×1	62	75~125	1200	335	238	130	193	444
	SMT-S(D)490	490	0.54×4P	0.65×4P	4.6	5.6	0.33×4P	0.4×4P	16.7	20.0	Ø5.0×1	64	75~125	1200	335	238	130	193	444
	SCT-S(D)500	500	0.54×4P	0.65×4P	4.6	5.6	0.33×4P	0.4×4P	16.7	20.0	Ø5.0×1	64	75~125	1200	335	238	130	193	444
0.92×4P			1.1×4P	7.0	8.4	0.33×4P	0.4×4P	16.7	20.0	Ø5.0×1	64	75~125	1200	335	238	130	193	452	
B	SMT-S(D)1000	1000	1.25×4P	1.5×4P	5.8	7.0	0.33×4P	0.4×4P	16.7	20.0	Ø7.1×1	82	75~125	1200	295	335	139	212	440
	SMT-S(D)1800D	1800	1.25×4P	1.5×4P	2.9	3.5	0.33×4P	0.4×4P	15.8	19.0	Ø7.1×2	102	100~150	1500	295	365	140	245	530
	SMT-S(D)2000D	2000	1.25×4P	1.5×4P	2.9	3.5	0.33×4P	0.4×4P	15.8	19.0	Ø7.1×2	102	100~150	1500	295	365	140	245	530



A-Frame 250~500kg

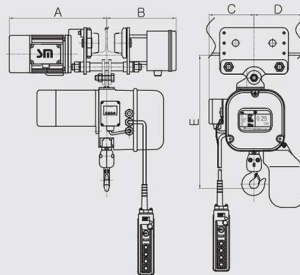

B-Frame 1000~3000kg

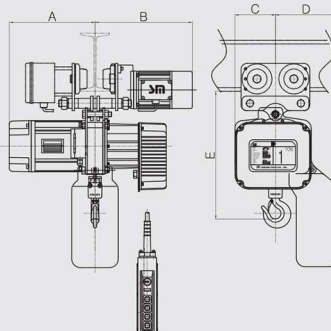



- Motors and brakes that boast powerful and long life
- Aluminum alloy frame that minimizes weight
- Voltage operation mode that minimizes the human body electric shock
- It using a high strength and stability RUD(Made in Germany), FED(Made in Japan)
- Deceleration of the structure and durable material benefits that boasts ultra-quiet
- Uniform production control system to produce quality



Chain hoist
Inverter Type
IV series

Frame	Model	Capacity (kg)	Hoisting Motor [Single]				Load Chain (mm×Falls)	Net. Weight (kg)	Dimension				
			Power(kw)×Pole		Speed(m/min)				Single				
			50Hz	60Hz	50Hz	60Hz			A	B	C	D	E
B	SMO-1000-IV	1000	1.25×4P	1.5×4P	1.2~5.8	1.5~7.0	Ø7.1×1	68	295	345	347	250	440
	SMO-1250-IV	1250	1.7×4P	2.0×4P	1.2~5.8	1.5~7.0	Ø7.1×1	68	295	345	347	250	440
	SMO-1500-IV	1500	2.1×4P	2.5×4P	1.6~6.7	2.0~8.0	Ø8.0×1	78	325	345	215	261	490
	SMO-1800D-IV	1800	1.25×4P	1.5×4P	0.6~2.9	0.7~3.5	Ø7.1×2	83	295	345	260	291	552
	SMO-2000D-IV	2000	1.25×4P	1.5×4P	0.6~2.9	0.7~3.5	Ø7.1×2	83	295	345	260	291	552
	SMO-2500D-IV	2500	1.7×4P	2.0×4P	0.6~2.9	0.7~3.5	Ø7.1×2	83	295	345	347	291	552
	SMO-3000D-IV	3000	2.1×4P	2.5×4P	0.8~3.3	1.0~4.0	Ø8.0×2	88	325	345	215	306	660



B-Frame 1000~1500kg

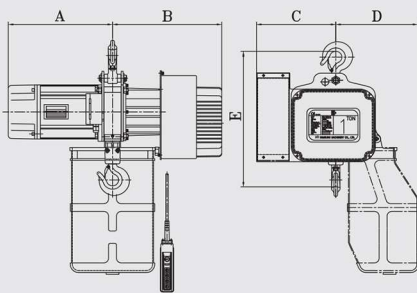

B-Frame 2000~3000kg

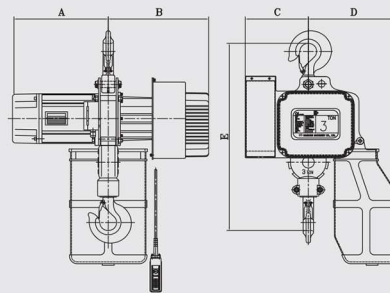

Frame	Model	Capacity (kg)	Hoisting Motor [Single]				Traversing Motor				Load Chain (mm×Falls)	Net. Weight (kg)	I-Beam Width (mm)	Min. Radius For Curve (mm)	Dimension				
			Power(kw)×Pole		Speed(m/min)		Power(kw)×Pole		Speed(m/min)						Single				
			50Hz	60Hz	50Hz	60Hz	50Hz	60Hz	50Hz	60Hz					A	B	C	D	E
B	SMT-1000-IV	1000	1.25×4P	1.5×4P	1.2~5.8	1.5~7.0	0.33×4P	0.4×4P	3~16.7	4~20	Ø7.1×1	89	75~125	1200	295	316	340	304	440
	SMT-1250-IV	1250	1.7×4P	2.0×4P	1.2~5.8	1.5~7.0	0.33×4P	0.4×4P	3~16.7	4~20	Ø7.1×1	89	75~125	1200	295	316	340	304	440
	SMT-1500-IV	1500	2.1×4P	2.5×4P	1.6~6.7	2.0~8.0	0.33×4P	0.4×4P	3~15	3.5~18	Ø8.0×1	97	100~150	1500	325	321	351	231	460
	SMT-1800D-IV	1800	1.25×4P	1.5×4P	0.6~2.9	0.7~3.5	0.33×4P	0.4×4P	3~15	3.5~18	Ø7.1×2	109	100~150	1500	295	321	351	231	530
	SMT-2000D-IV	2000	1.25×4P	1.5×4P	0.6~2.9	0.7~3.5	0.33×4P	0.4×4P	3~15	3.5~18	Ø7.1×2	109	100~150	1500	295	321	351	2321	530
	SMT-2500D-IV	2500	1.7×4P	2.0×4P	0.6~2.9	0.7~3.5	0.33×4P	0.4×4P	3~15	3.5~18	Ø7.1×2	109	100~150	1500	295	321	351	231	530
	SMT-3000D-IV	3000	2.1×4P	2.5×4P	0.8~3.3	1.0~4.0	0.33×4P	0.4×4P	3~15	3.5~18	Ø8.0×2	112	100~150	1500	325	321	351	231	610



B-Frame 1000~1500kg

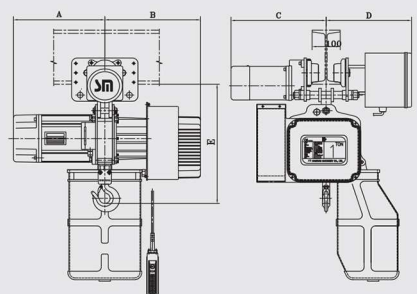

B-Frame 2000~3000kg

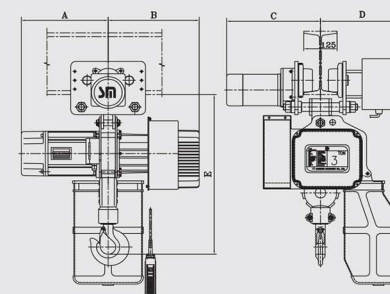



- Motors and brakes that boast powerful and long life
- Aluminum alloy frame that minimizes weight
- Voltage operation mode that minimizes the human body electric shock
- It using a high strength and stability RUD(Made in Germany), FED(Made in Japan)
- Deceleration of the structure and durable material benefits that boasts ultra-quiet
- Uniform production control system to produce quality

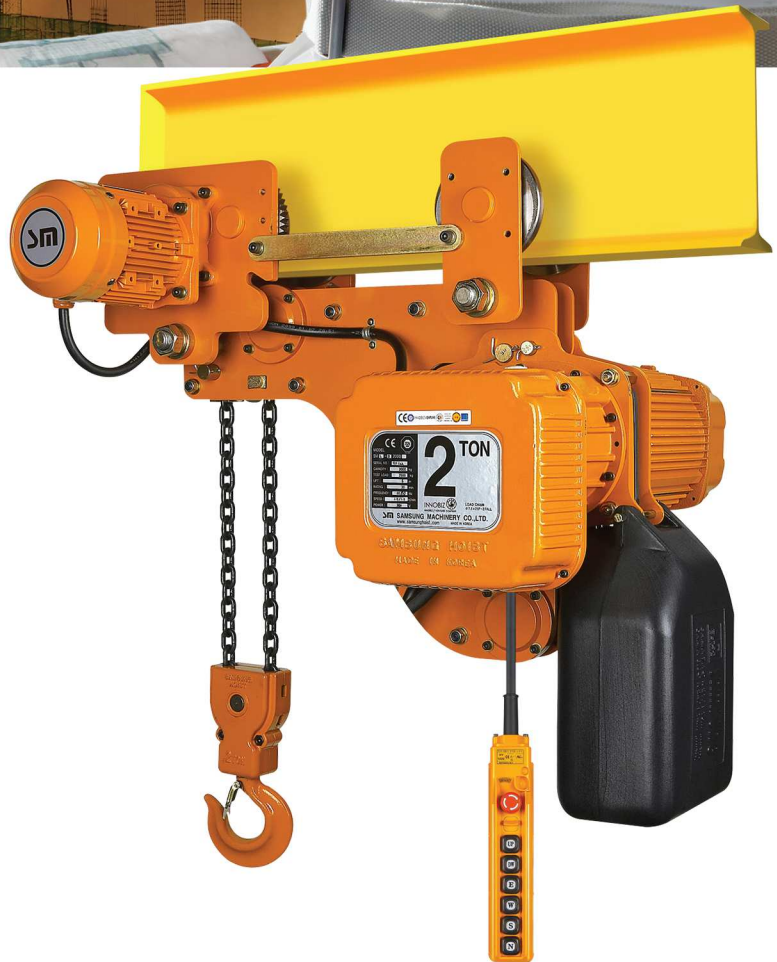

Chain hoist
Special Type
SML series

LOW HEAD TYPE

Frame	Model	Capacity (kg)	Hoisting Motor [Single]				Hoisting Motor [Dual]				Traversing Motor				Load Chain (mm×Falls)	Net Weight (kg)	I-Beam Width (mm)	Min.Radius For Curve (mm)	Dimension							
			Power(kw)×Pole		Speed(m/min)		Power(kw)×Pole		Speed(m/min)		Power(kw)×Pole		Speed(m/min)						Single							Dual
			50Hz	60Hz	50Hz	60Hz	50Hz	60Hz	50Hz	60Hz	50Hz	60Hz	50Hz	60Hz					A	B	C	D	E	F	A	
B	SML-S(D)1000	1000	1.25×4P	1.5×4P	5.8	7.0	1.25/0.63×4/8P	1.5/0.75×4/8P	5.8/2.9	7.0/3.5	0.33×4P (0.22×6P) [0.17×8P]	0.4×4P (0.27×6P) [0.2×8P]	16.7 (11.1) [8.3]	20.0 (13.3) [10.0]	Ø7.1×1	90	75~125	∞	335	245	132	212	320	802	350	
	SML-S(D)1250	1250	1.7×4P	2.0×4P	5.8	7.0	1.25/0.63×4/8P	1.5/0.75×4/8P	5.8/2.9	7.0/3.5					Ø7.1×1	90	75~125	∞	335	245	132	212	320	802	350	
	SML-S(D)1500	1500	2.1×4P	2.5×4P	6.7	8.0	2.1/1.25×4/8P	2.5/1.25×4/8P	6.7/3.4	8.0/4.0	0.33×4P (0.22×6P) [0.17×8P]	0.4×4P (0.27×6P) [0.2×8P]	15.8 (10.0) [7.9]	19.0 (12.0) [9.5]	Ø8.0×1	99	100~150	∞	350	245	140	216	390	820	350	
	SML-S(D)1800D	1800	1.25×4P	1.5×4P	2.9	3.5	1.25/0.63×4/8P	1.5/0.75×4/8P	2.9/1.5	3.5/1.8					Ø7.1×2	112	100~150	∞	350	245	140	212	385	810	350	
	SML-S(D)2000D	2000	1.25×4P	1.5×4P	2.9	3.5	1.25/0.63×4/8P	1.5/0.75×4/8P	2.9/1.5	3.5/1.8					Ø7.1×2	112	100~150	∞	350	245	140	212	385	810	350	
	SML-S(D)2500D	2500	1.7×4P	2.0×4P	2.9	3.5	1.25/0.63×4/8P	1.5/0.75×4/8P	2.9/1.5	3.5/1.8					Ø7.1×2	112	100~150	∞	350	245	140	212	385	810	350	
	SML-S(D)3000D	3000	2.1×4P	2.5×4P	3.4	4.0	2.1/1.25×4/8P	2.5/1.25×4/8P	3.4/1.7	4.0/2.0					Ø8.0×2	126	100~150	∞	350	245	140	216	490	820	350	
C	SML-S(D)2000	2000	2.9×4P	3.5×4P	6.8	8.2	2.9/1.5×4/8P	3.5/1.75×4/8P	6.8/3.4	8.2/4.1					Ø11.2×1	148	100~150	∞	364	313	140	272	510	890	390	
	SML-S(D)3000	3000	2.9×4P	3.5×4P	5.0	6.0	2.9/1.5×4/8P	3.5/1.75×4/8P	5.0/2.5	6.0/3.0					Ø11.2×1	148	100~150	∞	364	313	140	272	510	890	390	
	SML-S(D)5000D	5000	2.9×4P	3.5×4P	2.5	3.0	2.9/1.5×4/8P	3.5/1.75×4/8P	2.5/1.3	3.0/1.5	0.33×4P (0.22×6P) [0.17×8P]	0.4×4P (0.27×6P) [0.2×8P]	13.3 (8.3) [6.7]	16.0 (10.0) [8.0]	Ø11.2×2	213	125~175	∞	370	313	180	272	700	1010	390	

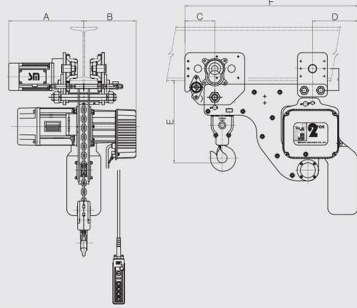

Traversing motor : 50Hz is standard 4P, 60Hz is standard 6P

EVENT TYPE

Frame	Model	Capacity (kg)	Hoisting Motor [Single]				Load Chain (mm×Falls)	Net Weight (kg)	Dimension				
			Power(kw)×Pole		Speed(m/min)				Single				
			50Hz	60Hz	50Hz	60Hz			A	B	C	D	E
B	SCO-500-EV	5000	1.25×4P	1.5×4P	9.0	10.8	Ø7.1×1	60	60	245	285	140	445
	SCO-1000-EV	1000	1.25×4P	1.5×4P	5.8	7.0	Ø7.1×1	60	60	245	285	140	445
	SCO-1500-EV	1500	2.1×4P	2.5×4P	6.7	8.0	Ø8.0×1	65	65	245	295	140	540

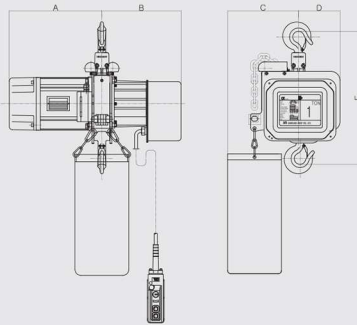

- Simple using for broadcasting & performance equipment, and easy to install and uninstall. Single & 3phases.
- Light weight, graceful appearance, and good transportation, comfortable handling.

SPECIAL TYPE

HIGH LIFTING TYPE



EXPLOSION PROOF



DOUBLE GIRDER TYPE





SAMSUNG HOIST CO., LTD.

FIRST FACTORY (HEAD OFFICE)

36, Hwanggeum 3-ro, Yangchon-eup, Gimpo-si, Gyeonggi-do, Korea

SECOND FACTORY

236-77, Gocheok-ro, Tongjin-eup, Gimpo-si, Gyeonggi-do, Korea

Tel. 82-31-989-8561~3

Fax. 82-31-989-8564

E-mail. sm@samsunghoist.com

www.samsunghoist.com



INDOTARA®

PT. INDOTARA PERSADA

Jakarta Head Office :
Graha Kencana Building Lt. 10 Suite 10F
Jl. Raya Perjuangan 88
Kebon Jeruk Jakarta Barat 11530
Phone : 021 - 583 55 398
Fax. : 021 - 583 55 400
email : sales@indotara.co.id

Surabaya Branch Office :
Bumi Mandiri Tower I Lt. 10 Suite 1008
Jl. Jend. Basuki Rachmat 129-137
Surabaya 60271
Phone : 031 - 535 3001
Fax. : 031 - 535 3002
email : sales-sby@indotara.co.id

Medan Branch Office :
Kompleks MMTC Warehouse Blok C-7
Jl. Pasar V, Pancing
Medan 20371
Phone : 061 - 800 323 24
Fax. : 061 - 800 322 25
email : sales-mdn@indotara.co.id

Bandung Branch Office :
Wisma HSBC Lt. 6 Suite B
Jl. Asia Afrika No. 116
Bandung, Jawa Barat 40112
Phone : 022 - 426 7333
Fax. : 022 - 426 7330
email : sales-bdg@indotara.co.id