

R

R Series

1-2.5 t

AC Electric Forklift Truck



R Series / HIGH EFFICIENCY
ENERGY SAVING

BOMAC



TOP1 FORKLIFT MANUFACTURER AND SALER

R

1-2.5t

R series
AC Electric Forklift Truck

R series | HIGH EFFICIENCY
ENERGY SAVING

Improved driver's view

- > Standard configuration of wide view mast, compact structure of mast and tube pulley block
- > Large arc of overhead guard and angle optimized grid tray enlarge driver's upper view.

Improved operating comfort

- > 25mm lowered pedal height, 100% enlarged accelerator panel and 40% enlarged brake pedal improve driver's foot operating comfort.
- > Super low torque steering unit makes steering light and easy.
- > Rear handle with horn button ensures safe and comfortable operation while reverse driving.
- > Mast and rear axle buffering improve driving comfort largely.
- > Ratchet hand brake has different brake force on slope and ground, reducing driver's fatigue.



Optimized maintainability and safety

- > Special side plate and top cover structure is easy for assembly and disassembly.
- > Highly-mounted rear axle increasing transversal stability by 2.1%.
- > Two driving modes offer optional choices to different working condition.
- > Automatic deceleration when steering is optional so as to ensure the operation safety.

High efficiency and energy-saving

- > The use of electric truck dedicated tire with pattern saves more than 10% of the energy during travelling.
- > LED lamps save 80% of the energy.
- > The professional matching design of the components prolongs the battery working time about 10%.

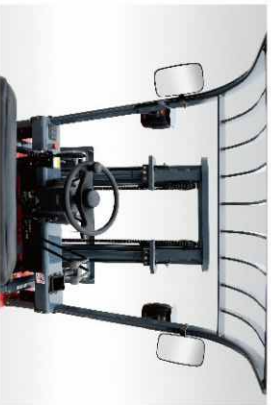

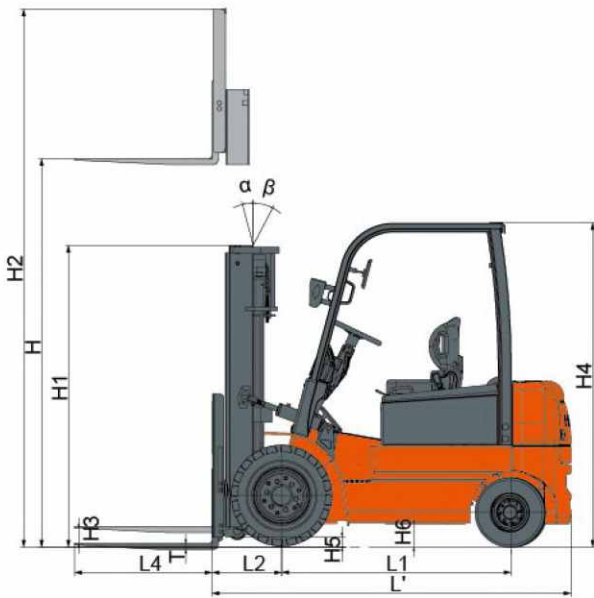

Ast: Right angle stacking aisle width

a: Clearance

b: Load Length

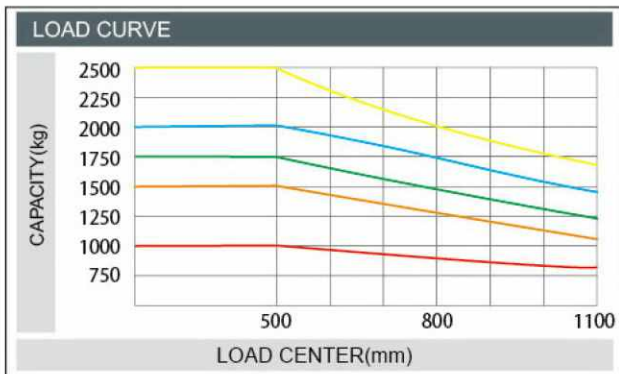
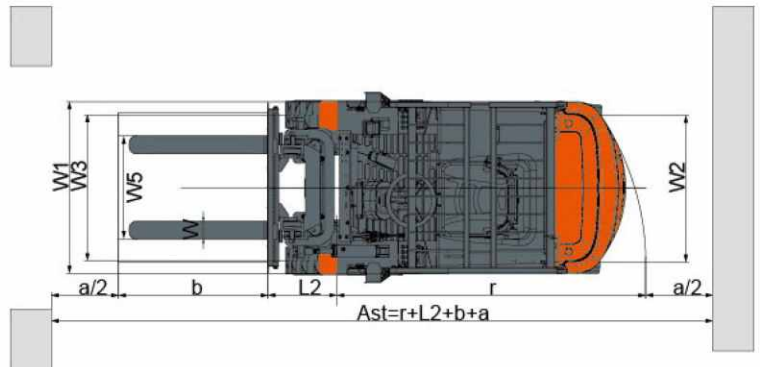

RE10

RE15

RE18

RE20

RE25

Note: The vertical axis stands for load capacity and the horizontal axis stands for load center which is calculated from the front surface of the forks to the gravity of the standard load. The standard load means a cubic with 1000mm edge length. When mast is tilted forward, using non-standard forks or loading large goods, the load capacity will be reduced. The load capacity of standard mast at different load center can be known from this load chart.

WIDE VIEW MAST

Mast model	Max lifting height (mm)	Load capacity (load center 500mm)(kg)					Mast overall height (fork to the ground)(mm)		Service weight(kg)					Mast tilt angle (°)α/β	
		1t	1.5t	1.8t	2t	2.5t	1-1.8t	2-2.5t	1t	1.5t(A)	1.5t(C)	1.8t	2t		2.5t
M200	2000	1000	1500	1750	2000	2500	1495	1500	2615	2885	2915	3085	3990	4140	6/12
M250	2500	1000	1500	1750	2000	2500	1745	1750	2645	2915	2945	3115	4035	4185	6/12
M300	3000	1000	1500	1750	2000	2500	1995	2000	2680	2950	2980	3250	4080	4230	6/12
M330	3300	1000	1500	1750	2000	2500	2145	2150	2700	2970	3000	3170	4105	4255	6/12
M350	3500	1000	1500	1750	2000	2500	2245	2250	2710	2980	3010	3180	4125	4275	6/12
M370	3700	1000	1500	1750	2000	2500	2345	2350	2725	2995	3025	3195	4140	4290	6/6
M400	4000	1000	1500	1700	2000	2450	2545	2550	2775	3045	3075	3245	4200	4350	6/6
M425	4250	1000	1400	1650 *1750	1850	2250	2670	2675	2790	3060	3090	3260	4225	4375	6/6 *6/12
M450	4500	950	1350	1550 *1700	1800	2150	2795	2800	2805	3075	3105	3275	4250	4400	6/6 *6/12
M500	5000	930	1000	1000	1600	1600	3045	3050	2840	3110	3140	3310	4295	4445	6/6 *6/6
M550	5500	900	*1250	900	*1600	1500	3345	3350	2900	3170	3200	3370	4370	4520	*3/6
M600	6000	600 *850	*1150	600	*1500	950	3595	3600	2930	3200	3230	3400	4420	4570	*3/6

NOTE: (1) * refers to rated capacity with double tires.

R 1-2.5t R series AC Electric Forklift Truck



Manufacturer's Data and Design Characteristics

Character		BOMAC											
1.01	Manufacturer	RE10	RE15	RE15	RE18	RE20	RE25	RE20	RE25	RE20	RE25	RE20	RE25
1.02	Model	A1/A2	A1/A2	C1/C2	A1/A2	C1/C2	A1/A2	C1/C2	A1/A2	C1/C2	A1/A2	C1/C2	A1/A2
1.03	Configuration number	1000	1500	1500	1750	2000	2600	2000	2600	2000	2600	2000	2600
1.04	Rated capacity	Q	c	mm	mm	mm	mm	mm	mm	mm	mm	mm	mm
1.05	Load center distance	500	500	500	500	500	500	500	500	500	500	500	500
1.06	Power mode	Battery	Battery	Battery	Battery	Battery	Battery	Battery	Battery	Battery	Battery	Battery	Battery
1.07	Driving mode	Sealed	Sealed	Sealed	Sealed	Sealed	Sealed	Sealed	Sealed	Sealed	Sealed	Sealed	Sealed
1.08	Wheel base	L1	mm	1280	1390	1390	1535	1535	1535	1535	1535	1535	1535
Type		Pneumatic											
2.01	Type	Pneumatic											
2.02	Wheel number(front/rear)	W3	W3	W3	W3	W3	W3	W3	W3	W3	W3	W3	W3
2.03	Front wheel base	W2	W2	W2	W2	W2	W2	W2	W2	W2	W2	W2	W2
2.04	Rear wheel base	W1	W1	W1	W1	W1	W1	W1	W1	W1	W1	W1	W1
2.05	Tyre (front)	6.50-10-10PR	6.50-10-10PR	6.50-10-10PR	6.50-10-10PR	6.50-10-10PR	6.50-10-10PR	6.50-10-10PR	6.50-10-10PR	6.50-10-10PR	6.50-10-10PR	6.50-10-10PR	6.50-10-10PR
2.06	Tyre(rear)	16×6-8-10PR	16×6-8-10PR	16×6-8-10PR	16×6-8-10PR	16×6-8-10PR	16×6-8-10PR	16×6-8-10PR	16×6-8-10PR	16×6-8-10PR	16×6-8-10PR	16×6-8-10PR	16×6-8-10PR
Size		Pneumatic											
3.01	Front overhang	L2	mm	410	410	410	410	410	410	410	410	410	410
3.02	Mast tilt angle, front/rear	α/β	°	6/12	6/12	6/12	6/12	6/12	6/12	6/12	6/12	6/12	6/12
3.03	Height with mast retraction	H1	mm	1995	1995	1995	1995	1995	1995	1995	1995	1995	1995
3.04	Free lifting height	H3	mm	150	150	150	170	170	170	170	170	170	170
3.05	Max. Lifting height	H	mm	3000	3000	3000	3000	3000	3000	3000	3000	3000	3000
3.06	Max. Height under working condition	H2	mm	4040	4040	4040	4042	4042	4042	4042	4042	4042	4042
3.07	Overhead guard height	H4	mm	2130	2130	2130	2130	2130	2130	2130	2130	2130	2130
3.08	Fork size/thickness/width/length	TWxLxL4	mm	32 × 100 × 770	35 × 100 × 920	35 × 100 × 920	35 × 100 × 920	35 × 100 × 920	35 × 100 × 920	35 × 100 × 920	35 × 100 × 920	35 × 100 × 920	35 × 100 × 920
3.09	Fork arm center, din standard	L'	mm	2065	2065	2065	2175	2175	2175	2175	2175	2175	2175
3.10	Truck body length (fork excluded)	W1	mm	1070	1070	1070	1070	1070	1070	1070	1070	1070	1070
3.11	Truck body width	F	mm	1770	1770	1770	1880	1880	1880	1880	1880	1880	1880
3.12	Turning radius	H5	mm	110	110	110	110	110	110	110	110	110	110
3.13	Clearance between mast and ground	H6	mm	120	120	120	120	120	120	120	120	120	120
3.14	Clearance between wheel base center and ground(loaded)	As1	mm	3390	3390	3390	3490	3490	3490	3490	3490	3490	3490
3.15	Right angle stacking aisle width (gallet1000x1000mm, clearance 200mm)	As1	mm	3590	3590	3590	3690	3690	3690	3690	3690	3690	3690
3.16	Right angle stacking aisle width (gallet1200x1200mm, clearance 200mm)	As1	mm	3590	3590	3590	3690	3690	3690	3690	3690	3690	3690
3.17	Lateral fork adjustment(outside of forks)/max./min.	As1	mm	960/200	960/200	960/200	960/200	960/200	960/200	960/200	960/200	960/200	960/200
Performance		Pneumatic											
4.01	Travelling speed, loaded/unloaded	km/h	14/15	14/15	14/15	14/15	14/15	14/15	14/15	14/15	14/15	14/15	14/15
4.02	Lifting speed, loaded/unloaded	m/s	0.29/0.45	0.27/0.45	0.27/0.45	0.28/0.53	0.28/0.53	0.28/0.53	0.28/0.53	0.28/0.53	0.28/0.53	0.28/0.53	0.28/0.53
4.03	Lowering speed	m/s	0.45	0.45	0.45	0.45	0.45	0.45	0.45	0.45	0.45	0.45	0.45
4.04	Gradeability (loaded)	%	18	17	17	15	15	15	15	15	15	15	15
4.05	Max. Traction force (loaded)	N	7800	8600	8600	9600	12300	12300	12300	12300	12300	12300	12300
4.06	Acceleration time (10m) loaded/unloaded	s	5.2/5.0	5.4/5.2	5.4/5.2	5.6/5.4	5.6/5.4	5.6/5.4	5.6/5.4	5.6/5.4	5.6/5.4	5.6/5.4	5.6/5.4
Weight		Pneumatic											
5.01	Total weight (with without battery)	kg	2890/2030	2950/2300	2960/2220	3150/2390	4080/3080	4080/3080	4080/3080	4080/3080	4080/3080	4080/3080	4080/3080
5.02	Axle load: unloaded, front/rear	kg	1215/1465	1330/1620	1445/1535	1450/1700	1960/1200	1960/1200	1960/1200	1960/1200	1960/1200	1960/1200	1960/1200
5.03	Axle load: loaded, front/rear	kg	3080/600	3900/550	3930/550	4400/500	5220/960	5220/960	5220/960	5220/960	5220/960	5220/960	5220/960
Battery		Pneumatic											
6.01	Battery voltage/capacity K5	V/Ah	48/400	48/400	48/480	48/480	48/600	48/600	48/600	48/600	48/600	48/600	48/600
6.02	Battery weight	kg	650(600-1000)	650(600-1000)	760(700-1000)	760(700-1000)	1000(950-1300)	1000(950-1300)	1000(950-1300)	1000(950-1300)	1000(950-1300)	1000(950-1300)	1000(950-1300)
6.03	Battery, din standard	43S31A	43S31A	43S31A	43S31A	43S31A	43S31A	43S31A	43S31A	43S31A	43S31A	43S31A	43S31A
Motor and controller		Pneumatic											
7.01	Drive motor power-60 minutes	kW	8.0	8.0	8.0	8.0	11.1	11.1	11.1	11.1	11.1	11.1	11.1
7.02	Lifting motor power-15 minutes	kW	7.5	7.5	7.5	8.6	10.5	10.5	10.5	10.5	10.5	10.5	10.5
7.03	Drive motor controlling mode	MOSFET/AC	MOSFET/AC	MOSFET/AC	MOSFET/AC	MOSFET/AC	MOSFET/AC	MOSFET/AC	MOSFET/AC	MOSFET/AC	MOSFET/AC	MOSFET/AC	MOSFET/AC
7.04	Lifting motor controlling mode	MOSFET/DC	MOSFET/DC	MOSFET/DC	MOSFET/DC	MOSFET/DC	MOSFET/DC	MOSFET/DC	MOSFET/DC	MOSFET/DC	MOSFET/DC	MOSFET/DC	MOSFET/DC
7.05	Service brake/servo brake	Hydraulic/Mechanical	Hydraulic/Mechanical	Hydraulic/Mechanical	Hydraulic/Mechanical	Hydraulic/Mechanical	Hydraulic/Mechanical	Hydraulic/Mechanical	Hydraulic/Mechanical	Hydraulic/Mechanical	Hydraulic/Mechanical	Hydraulic/Mechanical	Hydraulic/Mechanical
7.06	Hydraulic system working pressure	Mpa	14.5	14.5	14.5	17.5	17.5	17.5	17.5	17.5	17.5	17.5	17.5

NOTE: Detailed information about battery, please contact our salesman or engineer.

WIDE VIEW FULL FREE 2-STAGE MAST

Mast model	Max. lifting height (mm)	Load capacity (load center 500mm)(kg)					Mast overall height(mm)		Free lifting height (with backrest)(mm)		Service weight(kg)						Mast tilt angle (°)α/β
		1t	1.5t	1.8t	2t	2.5t	1-1.8t	2-2.5t	1-1.8t	2-2.5t	1t	1.5t(A)	1.5t(C)	1.8t	2t	2.5t	
ZM200	2000	1000	1500	1750	2000	2500	1495	1500	485	495	2660	2930	2960	3130	4000	4150	6/12
ZM250	2500	1000	1500	1750	2000	2500	1745	1750	735	745	2690	2960	2990	3160	4045	4195	6/12
ZM300	3000	1000	1500	1750	2000	2500	1995	2000	985	840	2725	2995	3025	3295	4095	4245	6/12
ZM330	3300	1000	1500	1750	2000	2500	2145	2150	1135	990	2750	3020	3050	3220	4115	4265	6/12
ZM350	3500	1000	1500	1750	2000	2500	2245	2250	1235	1090	2760	3030	3060	3230	4145	4295	6/12
ZM370	3700	1000	1500	1750	2000	2450	2345	2350	1335	1205	2775	3045	3075	3245	4160	4310	6/6
ZM400	4000	1000	1500	1750	2000	2400	2545	2550	1535	1390	2825	3095	3125	3295	4225	4375	6/6
ZM425	4250	1000	1400	1650 *1750	1850	2250	2670	2675	1660	1515	2840	3110	3140	3310	4250	4400	6/6 *6/12
ZM450	4500	950	1350	1550 *1700	1800	2150	2795	2800	1785	1640	2860	3130	3160	3330	4275	4425	6/6 *6/12
ZM500	5000	930	1000	1000	1600	1600	3045	3050	2035	1910	2895	3165	3195	3365	4320	4470	6/6 *6/6
ZM550	5500	900	950	950	1500	1500	3345	3350	2335	2190	2955	3225	3255	3425	4405	4555	*3/6
ZM600	6000	600	600	600	950	950	3595	3600	2585	2440	2990	3260	3290	3460	4455	4605	*3/6

NOTE: (1) * refers to rated capacity with double tires.
 (2) 1-1.8T: free lifted height 365mm increased without backrest.
 (3) 2-2.5T: free lifted height 290mm increased without backrest.

WIDE VIEW FULL FREE 3-STAGE MAST

Mast model	Max. lifting height (mm)	Load capacity (load center 500mm)(kg)					Mast overall height(mm)		Free lifting height (with backrest)(mm)		Service weight(kg)						Mast tilt angle (°)α/β
		1t	1.5t	1.8t	2t	2.5t	1-1.8t	2-2.5t	1-1.8t	2-2.5t	1t	1.5t(A)	1.5t(C)	1.8t	2t	2.5t	
ZSM360	3600	1000	1450	1750	2000	2400	1790	1795	695	795	2775	3045	3075	3245	4205	4355	6/6
ZSM400	4000	1000	1400	1600	1900	2300	1925	1920	910	920	2800	3070	3100	3270	4240	4390	6/6
ZSM435	4350	950	1300	1500 *1700	1850	2200	2040	2045	1025	1045	2820	3090	3120	3390	4275	4425	6/6
ZSM450	4500	950	1300	1500 *1650	1750	2100	2090	2095	1075	1095	2830	3100	3130	3300	4285	4435	6/6
ZSM470	4700	930	1280	1450 *1600	1720	2000	2160	2160	1075	1160	2850	3120	3150	3320	4305	4455	6/6
ZSM480	4800	920	1250	1400 *1580	1700	1950	2190	2195	1145	1195	2860	3130	3160	3330	4315	4465	6/6
ZSM500	5000	900	1000	1000	1600	1600	2290	2295	1275	1295	2880	3150	3180	3350	4345	4495	6/6
ZSM540	5400	750	800	800	1500	1500	2415	2420	1400	1420	2900	3170	3200	3370	4385	4535	3/6 *3/6
ZSM600	6000	550	550	550	950	950	2640	2645	1625	1645	2975	3245	3275	3445	4450	4600	3/6 *3/6
ZSM650	6500	*850	*1050	*1380	*1450	*1700	2840	2835	1815	1835	3010	3280	3310	3480	4505	4655	3/3 *3/3
ZSM700	7000	*650	*750	*900	*1000	*1100	3025	3105	2010	2105	3050	3320	3350	3520	4570	4720	*3/3

NOTE: (1) * refers to rated capacity with double tires.
 (2) 1-1.8T: free lifted height 480mm increased without backrest.
 (3) 1-1.8T: free lifted height 440mm increased without backrest when assembled with pulley block.
 (4) 2-2.5T: free lifted height 320mm increased without backrest.
 (5) 2-2.5T: free lifted height 90mm increased without backrest when assembled with pulley block



Renewable energy technologies

With the use of the excellent load-sensing steering system and AC controlling renewable energy technologies, the forklift is more energy-saving and the working hour of the battery is extended by 15%.

↑15%
THE PERFORMANCE OF BATTERY INCREASES

The reliable special instrument gives a complete display of the vital information, like operation status, fault detection, etc. It ensures the operator predominate the vehicle status more intuitive and convenient.

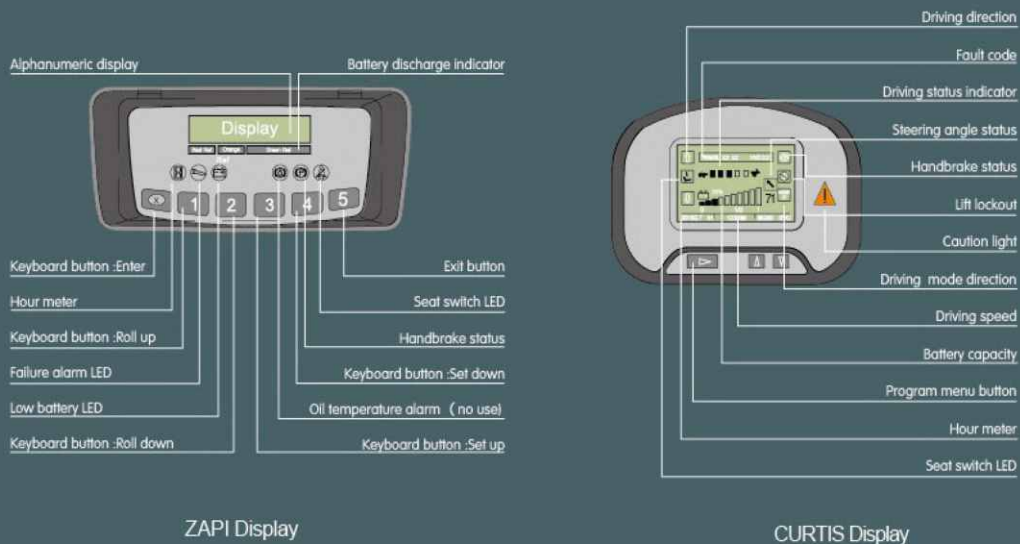

Standard configuration

- wide view basic mast
- standard fork
- II (III) stage fork arm carrier
- backrest
- control valve
- battery
- standard seat
- overhead guard
- overhead guard rain cover
- liquid crystal combined instrument
- pneumatic tyre
- traction pin
- driver's tool
- LED Lamp
- Horn alert function on rear handle

Optional device

- string rod
- driver's cab
- lifting hock
- cargo boom
- tip-over fork
- back view mirror
- side shifting
- paper roll clamp
- warning light (Flashing, totating, buzzing)
- solid tyre
- rear working light
- steel protection net
- multipurpose drum clamp
- load stabilizer
- widen fork arm carrier

- lengthening fork
- load pusher
- lengthening fork extension
- rotating flat clamp
- widen tyre protection device
- auxiliary hydraulic valve component
- tilting/steering cylinder jacket
- coloring tyre
- wide view two/three stage full free mast
- customer made color
- Turn automatic deceleration function
- Battery lifting sling



PT. INDOTARA PERSADA
 Graha Kencana Building Lt. 10 Suite 10F
 Jl. Raya Perjuangan No. 88
 Kebon Jeruk, Jakarta Barat 11530
 Phone : 021 - 583 55 398
 Fax. : 021 - 583 55 400
 E-mail. : sales@indotara.co.id
 Web. : www.indotara.co.id